

## VIGE1000

PT GUINCHO ELECTRICO 250/500KG - 1000W  
 ESP ELEVADOR ELECTRICO POR CABLE 250/500KG 860W  
 ING ELECTRIC WINCH 250/500KG 860W  
 FR PALAN ÉLECTRIQUE 250/500KG 860W

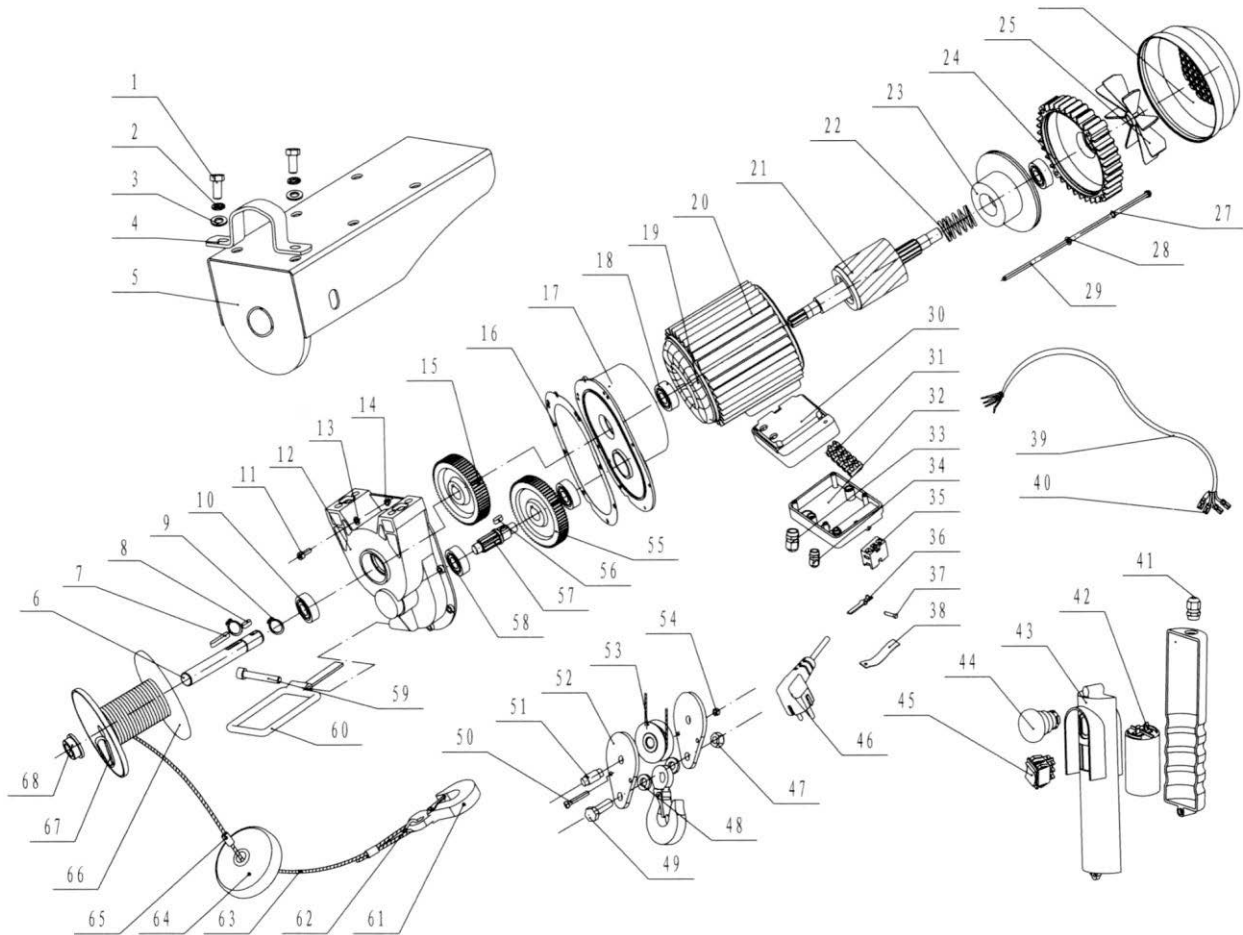

NUMERO	CÓDIGO	DESIGNAÇÃO
6	VIGE1000.1.01.006	VEIO (CARRETO)
12	VIGE1000.1.01.012	CAIXA (ENGRENAGENS)
15	VIGE1000.1.01.015	ENGRENAGEM
16	VIGE1000.1.01.016	JUNTA CAIXA ENGRENAGENS
17	VIGE1000.1.01.017	TAMPA CAIXA (ENGRENAGENS)
[19-20]	VIGE1000.1.01.019	ESTATOR
21	VIGE1000.1.01.021	ROTOR
22	VIGE1000.1.01.022	MOLA TRAVAO
23	VIGE1000.1.01.023	TRAVAO
24	VIGE1000.1.01.024	TAMPA DO VEIO
25	VIGE1000.1.01.025	VENTOINHA
26	VIGE1000.1.01.026	PROTECÇÃO (VENTOINHA)
35	VIGE1000.1.01.035	INTERRUPTOR SEGURANÇA
41	VIGE1000.1.01.041	CARCAÇA INFERIOR COMANDO
43	VIGE1000.1.01.043	CARCAÇA SUPERIOR COMANDO
45	VIGE1000.1.01.045	BOTAO SUBIDA/DESCIDA GUINCHO

55	VIGE1000.1.01.055	ENGRENAGEM
57	VIGE1000.1.01.057	VEIO (ENGRENAGEM)
[61-65]	VIGE1000.1.01.065	CABO AÇO COMPLETO
[61-67]	VIGE1000.1.01.066	ROLDANA COMPLETA
	VIGE1000.1.01.068	PORCA ENROLADOR DO CABO
[41-45]	VIGE1000.1.01.069	COMANDO COMPLETO